

NELSON™ HEAT TRACING SYSTEMS

HASK-S HAZARDOUS AREA SEAL KIT

FOR DIVISION 1 CABLE SPLICE TERMINATION & EXPLOSION PROOF SEAL

INSTALLATION INSTRUCTIONS

DESCRIPTION

The HASK-S Hazardous Area Seal Kit provides the cable termination and explosion proof seal parts needed to make all the in-line splice electrical connections associated with all Nelson Heat Tracing Systems' self-regulating heater cables.

KIT CONTENTS

- | | |
|--------------------|----------------------|
| 1 Junction Box | 2 Male Adapters |
| 1 Box Cover Gasket | 2 Reducer Bushings |
| 1 Tube of Silicone | 2 Power Terminations |
| 1 Sealing Compound | 1 Terminal Block |
| 1 X-Fiber | 2 Cable Entry Seals |
| 2 Pipe Clamps | 1 Conduit Plug |
| 2 Seal Fittings | |

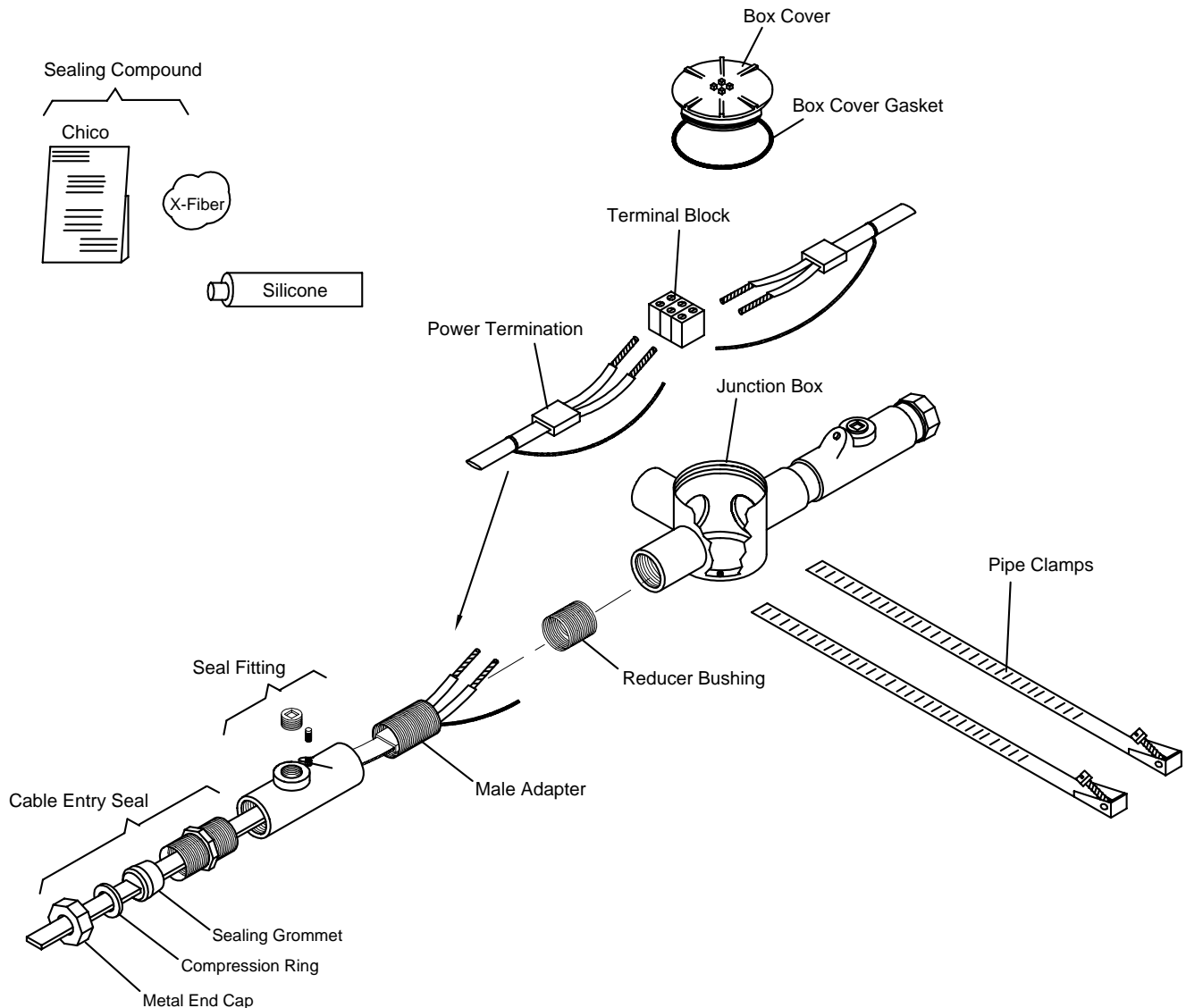

NELSON™ HEAT TRACING SYSTEMS

HASK-S HAZARDOUS AREA SEAL KIT

FOR DIVISION 1 CABLE SPLICE TERMINATION & EXPLOSION PROOF SEAL

INSTALLATION

INSTRUCTIONS

JUNCTION BOX CONNECTION

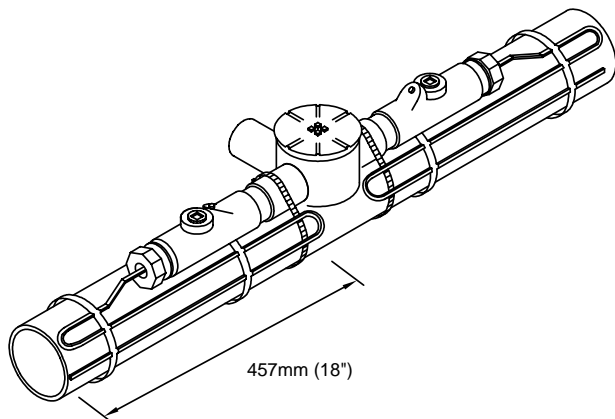

- 1 Allow 457mm (18") of heater cable for each side to compensate for heat loss of the termination kit.

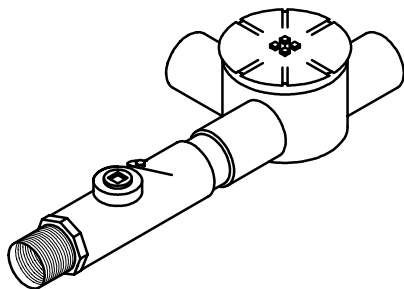

- 2 Thread the reducer bushing into the junction box. Then thread the male adapter into the reducer bushing. Finally, thread the seal fitting into the male adapter. Tighten to a minimum of 5 full threads of engagement.

Note: If the seal fitting is to be mounted in vertical position, mount with the slanted small hole plug upwards.

- 3 Remove the metal end cap, black compression ring and sealing grommet from the cable entry seal and thread the cable entry seal into the seal fitting. Tighten to a minimum of 5 full threads of engagement.
- 4 Repeat steps 2-3 for the other seal fitting.

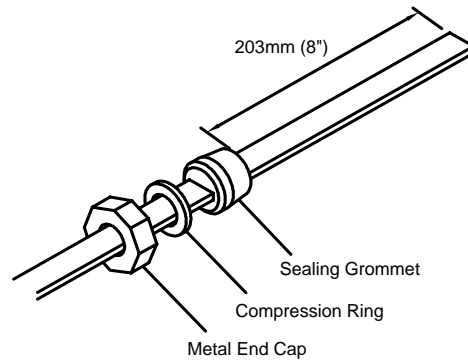

- 5 Slide a metal end cap, compression ring and sealing grommet over each heater cable. Position each sealing grommet 203mm (8") from each heater cable end.

Note: Each metal end cap, compression ring and sealing grommet must be oriented to fit correctly into each cable entry seal.

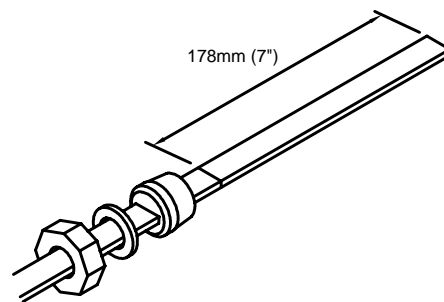

- 6 Prepare all heater cables for termination. Proceed to "Overjacket Stripping Procedures" on sheet 3.

NELSON™ HEAT TRACING SYSTEMS

HASK-S HAZARDOUS AREA SEAL KIT FOR DIVISION 1 CABLE SPLICE TERMINATION & EXPLOSION PROOF SEAL

INSTALLATION INSTRUCTIONS

OVERJACKET STRIPPING PROCEDURES

⚠ WARNING:
DO NOT CUT BRAID

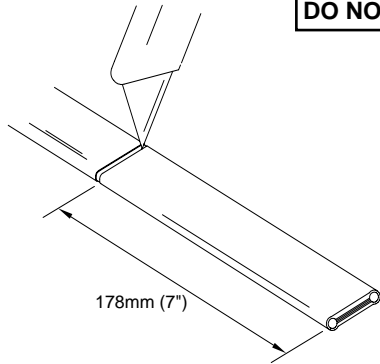

- 1 Lightly cut around heater overjacket 178mm (7") from the end. Bend cable to break overjacket.
- 2 Lightly cut overjacket up the center between first cut mark and the cable end. Bend cable to break overjacket.

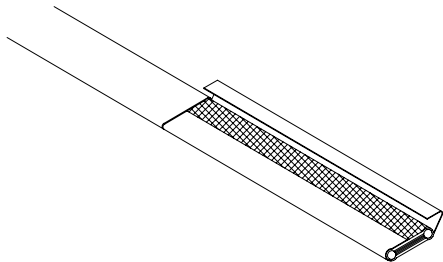

- 3 Remove overjacket from heater cable.

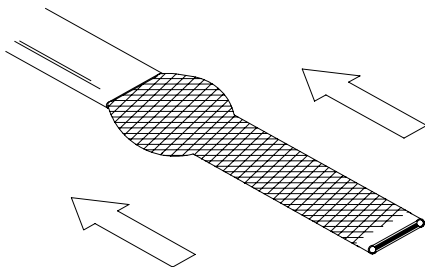

- 4 Move braid back toward the overjacket, creating a bulge.

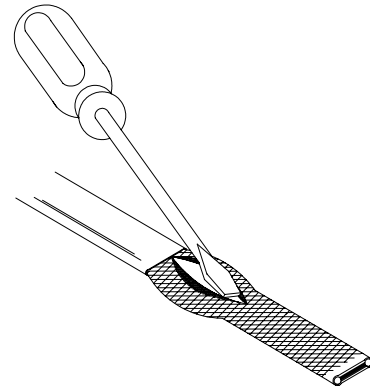

- 5 At the bulge, separate the braid to make an opening.

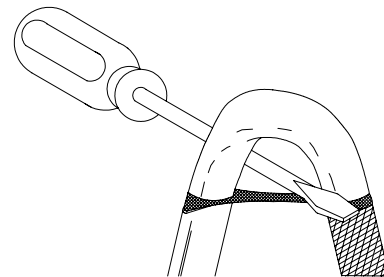

- 6 While bending the heater cable, work it through the braid opening.

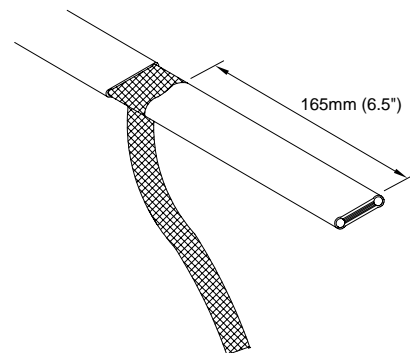

- 7 Pull the braid tight.
- 8 Proceed to "Outer Jacket Stripping Procedures" on sheet 4.

NELSON™ HEAT TRACING SYSTEMS

HASK-S HAZARDOUS AREA SEAL KIT FOR DIVISION 1 CABLE SPLICE TERMINATION & EXPLOSION PROOF SEAL

INSTALLATION INSTRUCTIONS

OUTER JACKET STRIPPING PROCEDURES

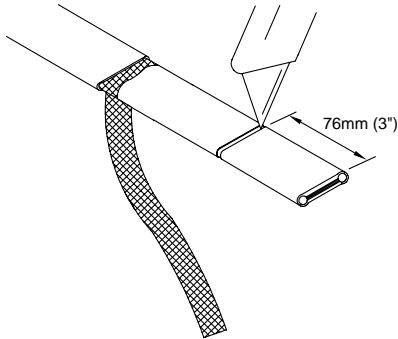

- 1 Lightly cut around heater outer jacket 76mm (3") from the end. Bend cable to break outer jacket.
- 2 Lightly cut the outer jacket up the center between the first cut mark & the cable end. Bend cable to break outer jacket.

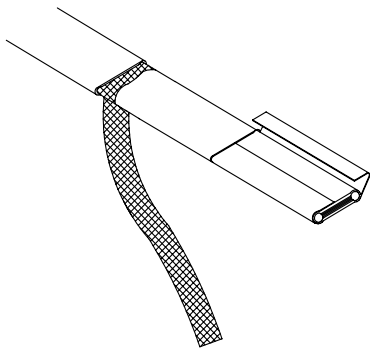

- 3 Remove the jacket from the heater cable.

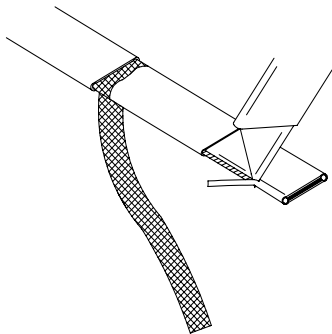

- 4 Shave the core material from the outside of each bus wire.

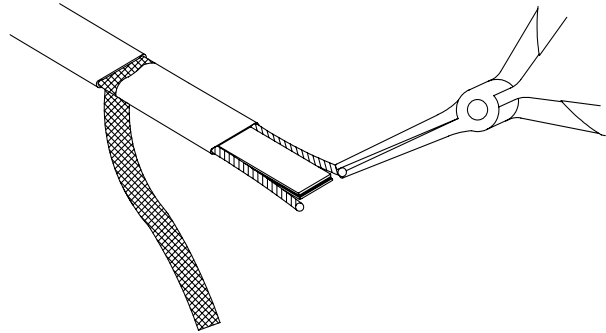

- 5 Starting at the end, pull each bus wire away from the core material.
- 6 Remove exposed core material.

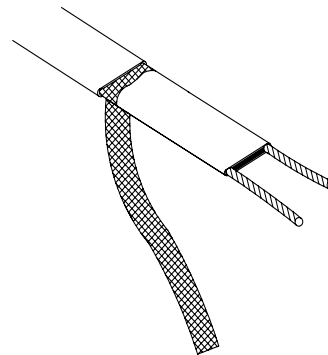

- 7 Cut 6mm (0.25") off the end of each bus wire.
- 8 Proceed to "Power Termination" on sheet 5.

⚠ WARNING:
DO NOT CUT BUS WIRES

NELSON™ HEAT TRACING SYSTEMS

HASK-S HAZARDOUS AREA SEAL KIT

FOR DIVISION 1 CABLE SPLICE TERMINATION & EXPLOSION PROOF SEAL

INSTALLATION
INSTRUCTIONS

POWER TERMINATION

⚠ WARNING:

- Bus wires must not touch or cross while inserting into power termination.
- Only power terminations specifically approved for the vendors style and type of heater cable must be used.

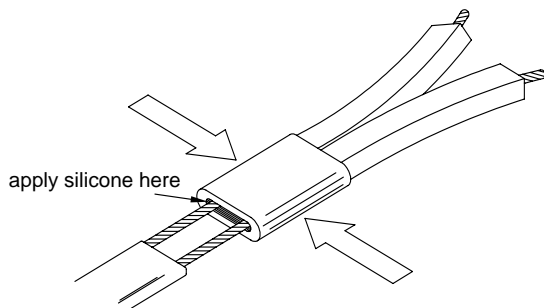

- 1 Insert bus wires into power termination.
- 2 Squeeze power termination opening and fill with silicone.

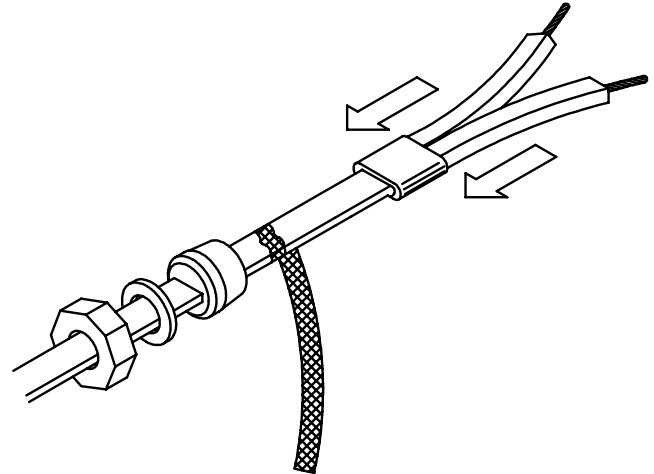

- 3 Push power termination to overlap jacket.
- 4 Proceed to "Seal Fitting Installation" on sheet 6.

NELSON™ HEAT TRACING SYSTEMS

HASK-S HAZARDOUS AREA SEAL KIT

FOR DIVISION 1 CABLE SPLICE TERMINATION & EXPLOSION PROOF SEAL

INSTALLATION
INSTRUCTIONS

SEAL FITTING INSTALLATION

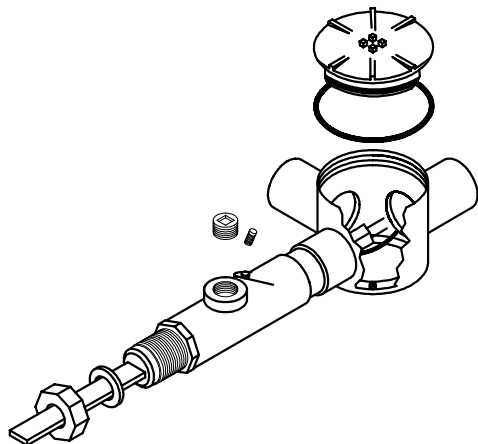

- 1 Remove box cover and box cover gasket from junction box; place a power termination through each cable entry seal and seal fitting. Slide forward until the sealing grommet is flush with the entry seal.

Note: The heater cable must be positioned in the seal fitting so the braid transition point is visible through the seal fitting opening. See Detail "A" on sheet 8 for example.

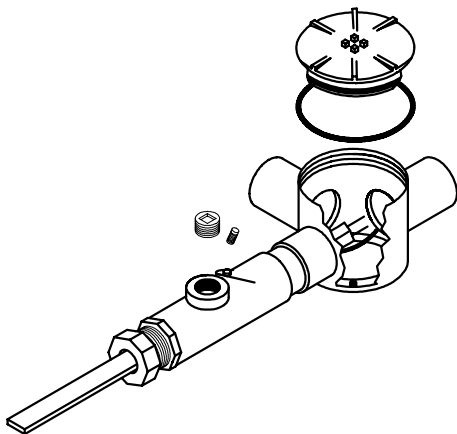

- 2 Slide the compression ring and metal end cap forward and thread onto the cable entry seal. Tighten to 51 foot pounds.
- 3 Repeat steps 1-2 for the other seal fitting.

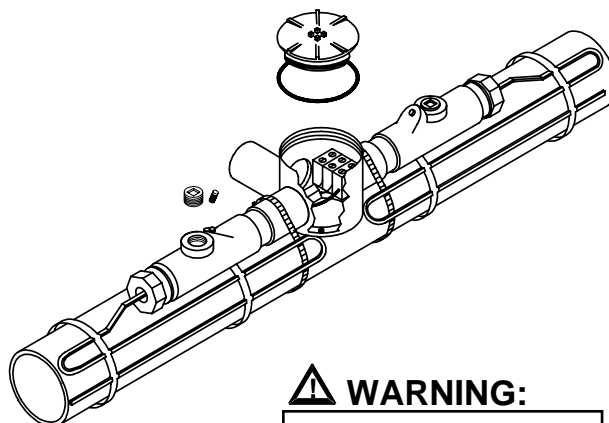

⚠ WARNING:

Do not install pipe clamps over the heater cables.

- 4 Mount the junction box to pipe using pipe clamps.
- 5 Connect bus wires to the terminal block. Connect ground braid from both heater cables to green ground screw.
- 6 Place the box cover gasket and box cover onto the junction box and plug the unused conduit opening using the conduit plug.
- 7 Proceed to "Sealing Compound Procedure" on sheet 7.

NELSON™ HEAT TRACING SYSTEMS

HASK-S HAZARDOUS AREA SEAL KIT

FOR DIVISION 1 CABLE SPLICE TERMINATION & EXPLOSION PROOF SEAL

INSTALLATION
INSTRUCTIONS

SEALING COMPOUND PROCEDURE

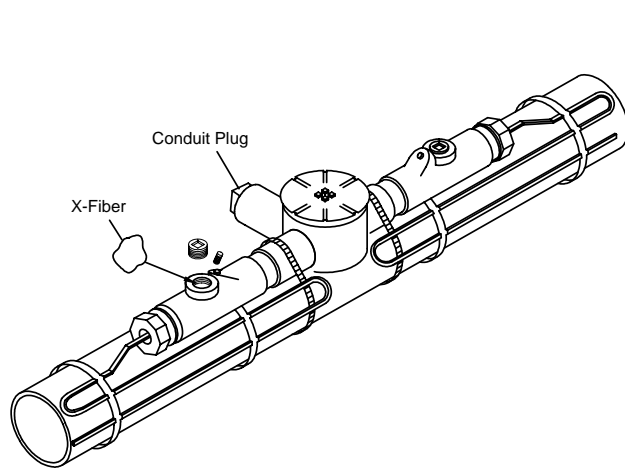

- 1 Center the heater cable in the conduit opening. Using the X fiber, pack around the heater cable forming a dam to hold the sealing compound.

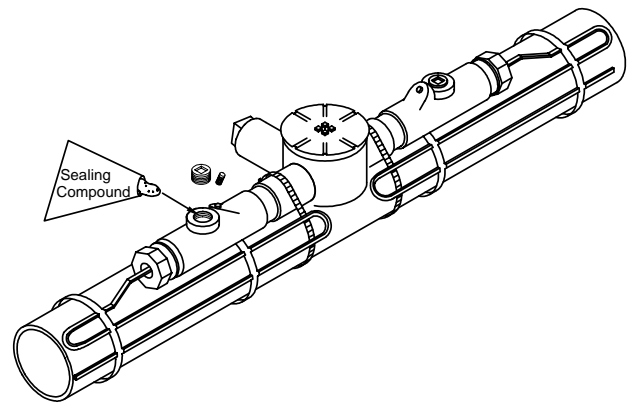

- 2 Mix the sealing compound according to instructions on the pouch, (knead to mix liquid and powder in pouch). Snip off a corner of the pouch and fill the seal.

⚠ WARNING:

Sealing compound must completely cover the braid transition point. See Detail "A" on sheet 8 for reference.

NELSON™ HEAT TRACING SYSTEMS

HASK-S HAZARDOUS AREA SEAL KIT FOR DIVISION 1 CABLE SPLICE TERMINATION & EXPLOSION PROOF SEAL

INSTALLATION INSTRUCTIONS

TEMPLATE

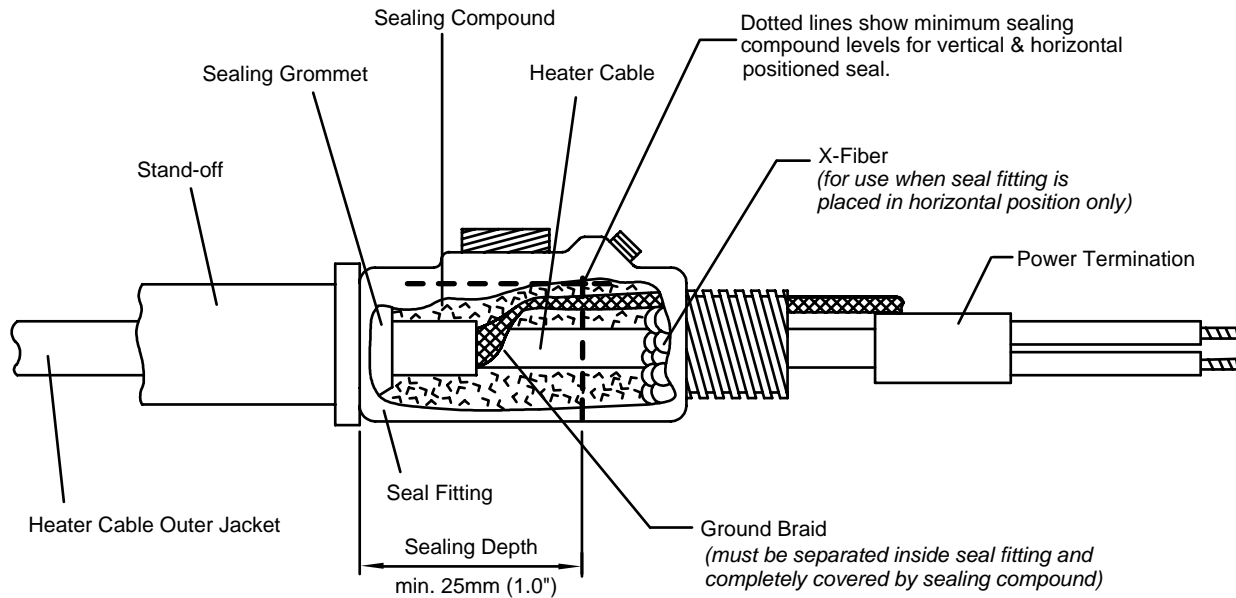
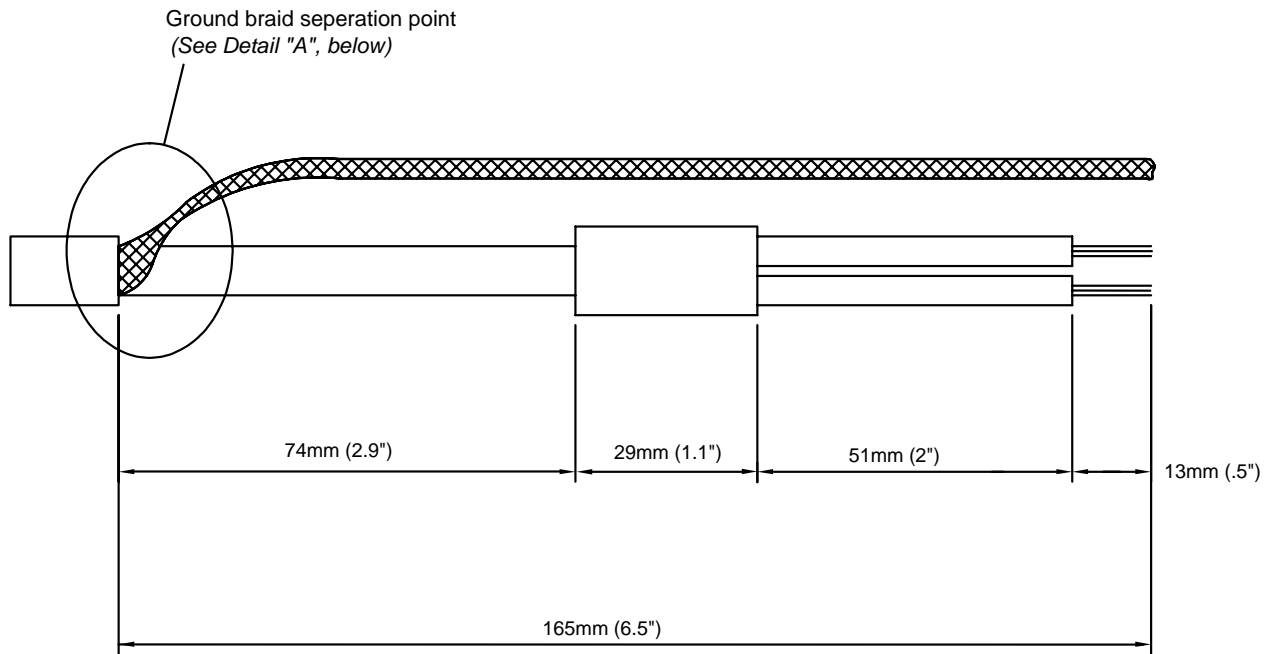

DETAIL "A"

Nelson Heat Tracing Systems products are supplied with a limited warranty. Complete Terms and Conditions may be found on Nelson's website at www.nelsonheaters.com.

P.O. BOX 726 ■ TULSA, OK 74101 ■ TEL 918-627-5530 ■ FAX 918-641-7336 ■ www.nelsonheaters.com